

ABE
EQUIPMENT



CraftCan Canning Lines

Automatic Canning Lines

CraftCan15

The CraftCan15 is designed to fill, lid and seam up to 15 cans per minute in a wide variety of aluminum cans with minimal downtime and maximum throughput. Engineered with our patented Servo Seamer and on-demand seam analysis, this line offers precision filling that is second to none. The CraftCan15 is innovative, versatile, and affordable; built to generate the profits your craft beverage deserves.

Precision Filling

- Exclusive one-piece fill head design for enhanced sanitary environment and increased fill level accuracy
- Proprietary CO₂ micro-burst action to better manage foam
- Purge Cycle - precision purge control means reduced dissolved oxygen pickup resulting in reliable oxygen evacuation
- Upgradeable to CraftCan35
- Average DO pickup: 15-25 PPB
- Nitrogen compatible

Quick-Change Lid Magazine

- Increase your efficiency

Servo Seamer Technology

- Patented Torque Monitor instantly inspects and assesses seam accuracy on every can
- System diagnostics available for remote troubleshooting

Post Rinse & Dryer Included

- Ensures cans are clean & dry for packaging or labeling

Small Footprint

- 8' length x 2' width fits in tight spaces
- Optional casters

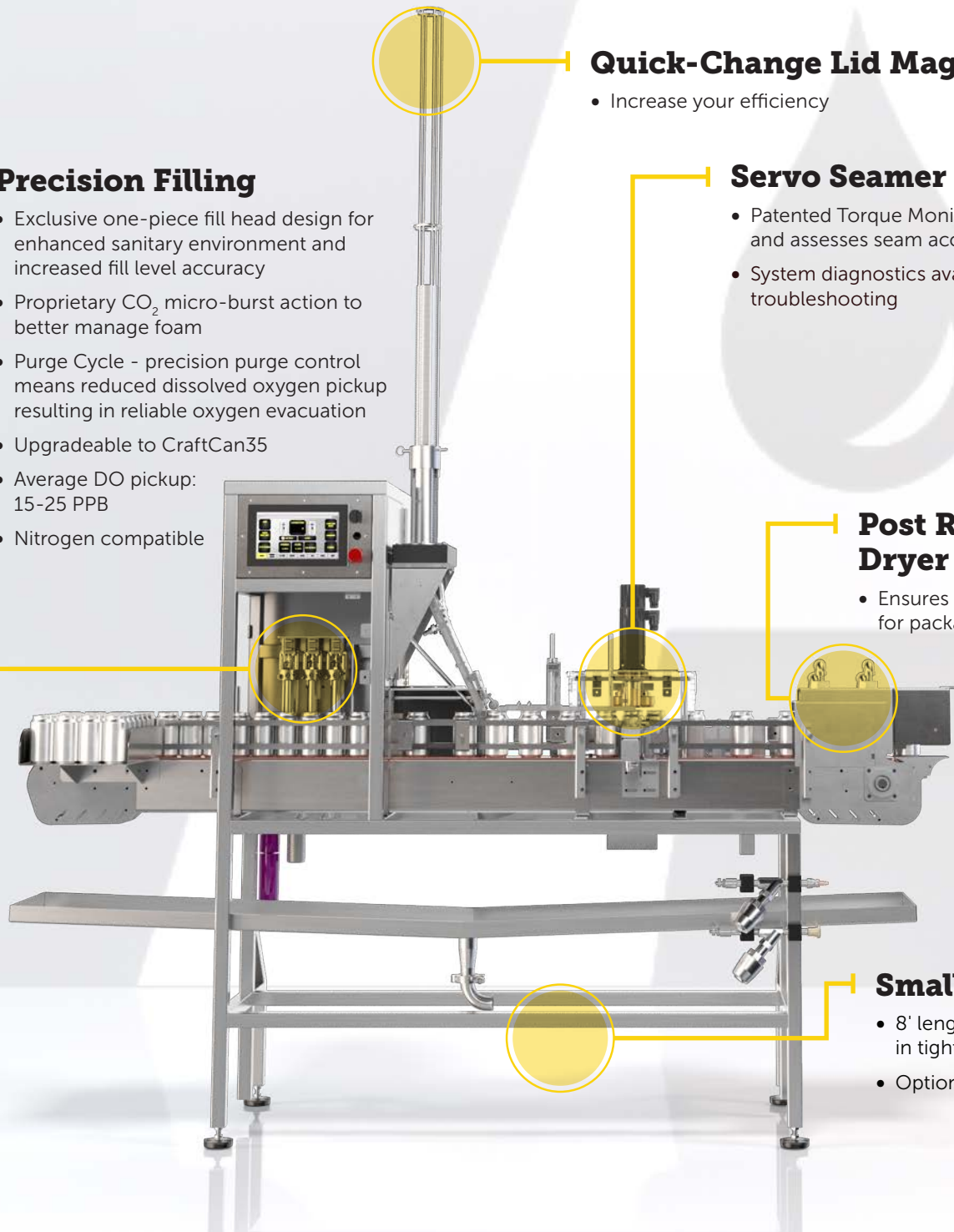

Fills up to 15 Cans Per Minute



CraftCan15

General Specifications

- Up to 15 CPM (based on 12 oz can)
- Electrical requirements: 208 V, 60 Hz, 1-Phase, 2 wire, 20 A, 12 A (connected load), 2.5 kVA, 2.1 kW average (other electrical options available)
- UL508A compliant control panel
- Water Requirements: 2 gpm @ 60 psi
- Air Requirements: 5 SCFM @ 100 psi
- Specifications may vary based on size and customization

Your Complete Package

Each CraftCan15 Canning Line that leaves our facility carries UL certification and an industry-leading five year limited warranty on the metal and welds. In addition to a comprehensive spare parts inventory, you'll receive superior customer support from our team in Lincoln, Nebraska with any ABE purchase.

Compatible Bottles/Closures

- Standard US sizes: 12 oz, 16 oz, 19.2 oz (24 oz options available)
- International sizes: 330 ml, 355 ml, 375 ml, 440 ml, 500 ml, 568 ml
- Slim/Sleek: 250 ml slim, 8 oz sleek, 12 oz sleek
- Lids: CDL-E, CDL-W, CDL+, SuperEnd, SuperEndDA+, B64, ISE
- Other sizes available upon request

Compatible Products

- YellowJacket Depalletizer
- Twist Rinse or Z-Rinse
- LabelMax Labeling Systems
- AutoPak Can Carrier
- And More!

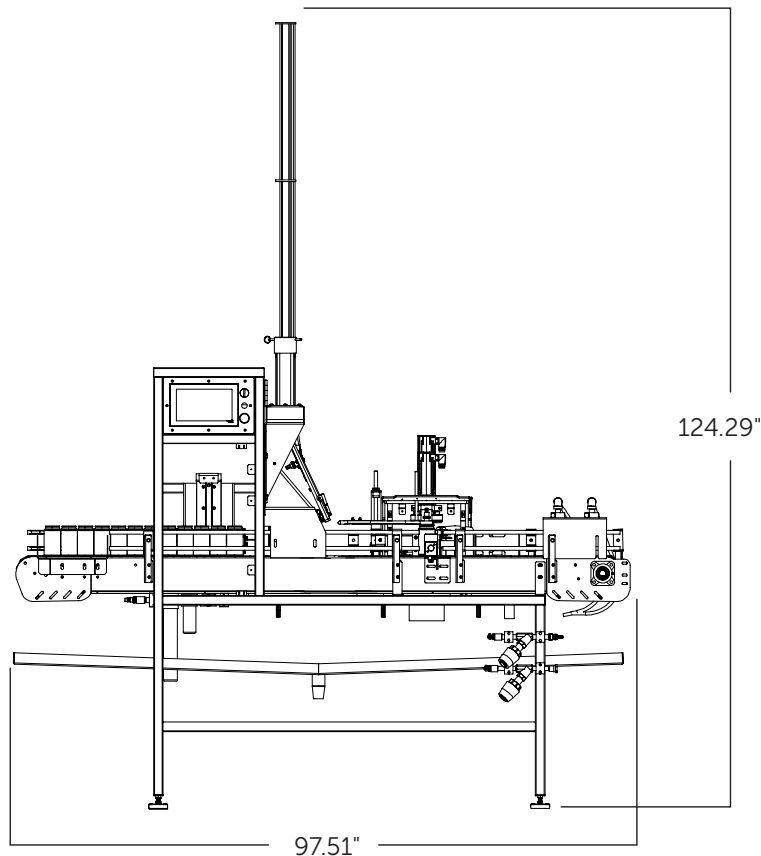

CraftCan35

The CraftCan35 is designed to fill, lid and seam up to 35 cans per minute in a wide variety of aluminum cans with minimal downtime and maximum throughput. Engineered with our patented Servo Seamer and on-demand seam analysis, this line offers precision filling that is second to none. The CraftCan35 is innovative, versatile, and affordable; built to generate the profits your craft beverage deserves.

Precision Filling

- Exclusive one-piece fill head design for enhanced sanitary environment and increased fill level accuracy
- Proprietary CO₂ micro-burst action to better manage foam
- Purge Cycle - precision purge control means reduced dissolved oxygen pickup resulting in reliable oxygen evacuation
- Average DO pickup 15-25 PPB
- Nitrogen compatible

Quick-Change Lid Magazine

- Increase your efficiency

Servo Seamer Technology

- Patented Torque Monitor instantly inspects and assesses seam accuracy on every can
- System diagnostics available for remote troubleshooting

Post Rinse & Dryer Included

- Ensures cans are clean & dry for packaging or labeling

Small Footprint

- 8' length x 2' width fits in tight spaces
- Optional casters

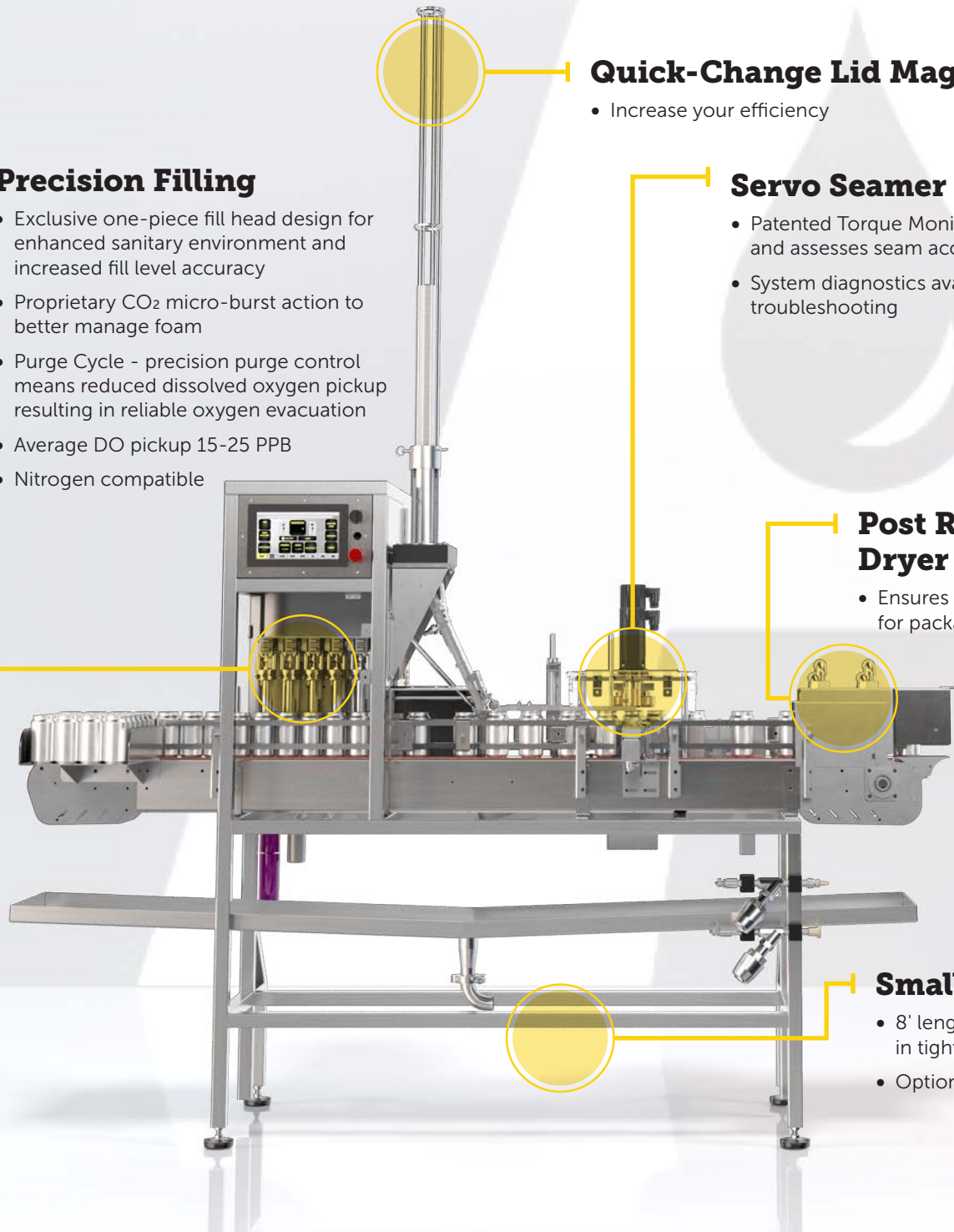

Fills up to 35 Cans Per Minute



CraftCan35

General Specifications

- Up to 35 CPM (based on 12 oz can)
- Electrical requirements: 208 V, 60 Hz, 1-phase, 2 wire, 20 A, 12 A (connected load), 2.5 kVA, 2.1 kW average (other electrical options available)
- UL508A compliant control panel
- Water Requirements: 2 gpm @ 60 psi
- Air Requirements: 5 scfm @ 100 psi
- Specifications may vary based on size and customization

Your Complete Package

Each CraftCan35 Canning Line that leaves our facility carries UL certification and an industry-leading five year limited warranty on the metal and welds. In addition to a comprehensive spare parts inventory, you'll receive superior customer support from our team in Lincoln, Nebraska with any ABE purchase.

Compatible Bottles/Closures

- Standard US sizes: 12 oz, 16 oz, 19.2 oz (24 oz options available)
- International sizes: 330 ml, 355 ml, 375 ml, 440 ml, 500 ml, 568 ml
- Slim/Sleek: 250 ml slim, 8 oz sleek, 12 oz sleek
- Lids: CDL-E, CDL-W, CDL+, SuperEnd, SuperEndDA+, B64, ISE
- Other sizes available upon request

Compatible Products

- YellowJacket Depalletizer
- TailGator Can Feed System
- Twist Rinse or Z-Rinse
- LabelMax Labeling Systems
- AutoPak Can Carrier
- And More!

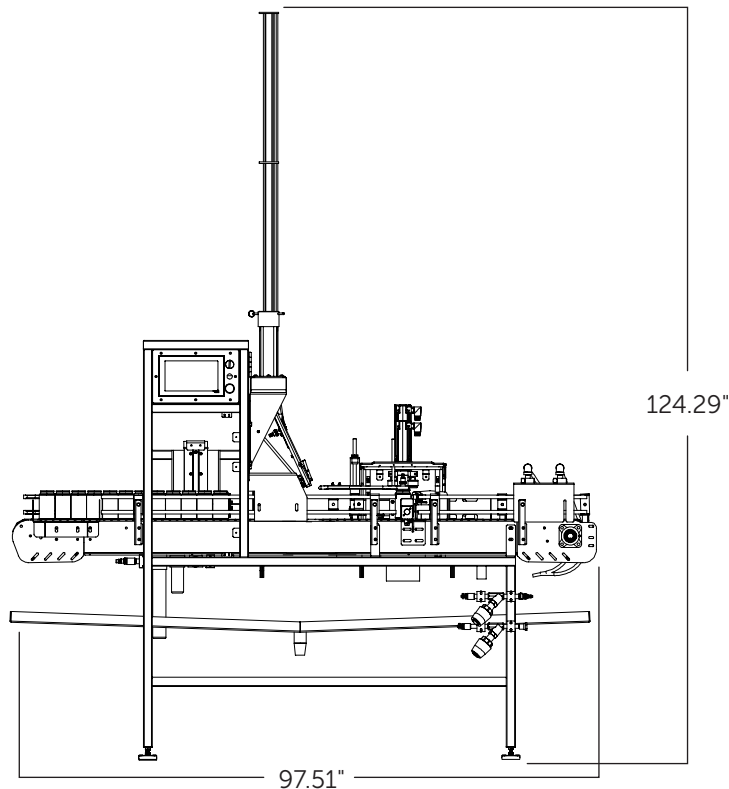

CraftCan Duo45

The CraftCan Duo45 features ABE Equipment's proprietary 8-valve design. The CraftCan Duo45 is easily upgradeable to a CraftCan Duo90, giving you the flexibility to grow with your business. This game-changing canning system is built with our patented Servo Seamer and on-demand seam analysis for precision filling that is second to none.

Speed and Precision

- Upgradeable to CraftCan Duo90
- Built-in CO₂ ports on one-piece stainless steel fill heads
- Rotary-can-indexing with on-screen micro adjustments for precise can seam positioning
- Proprietary recipe recall feature reduces setup time
- Average DO pickup 15-25 PPB
- Nitrogen compatible

Servo Seamer Technology

- Patented Torque Monitor instantly inspects and assesses seam accuracy on every can
- System diagnostics available for remote troubleshooting

Post Rinse & Dryer Included

- Ensures cans are clean & dry for packaging or labeling

Optional Casters

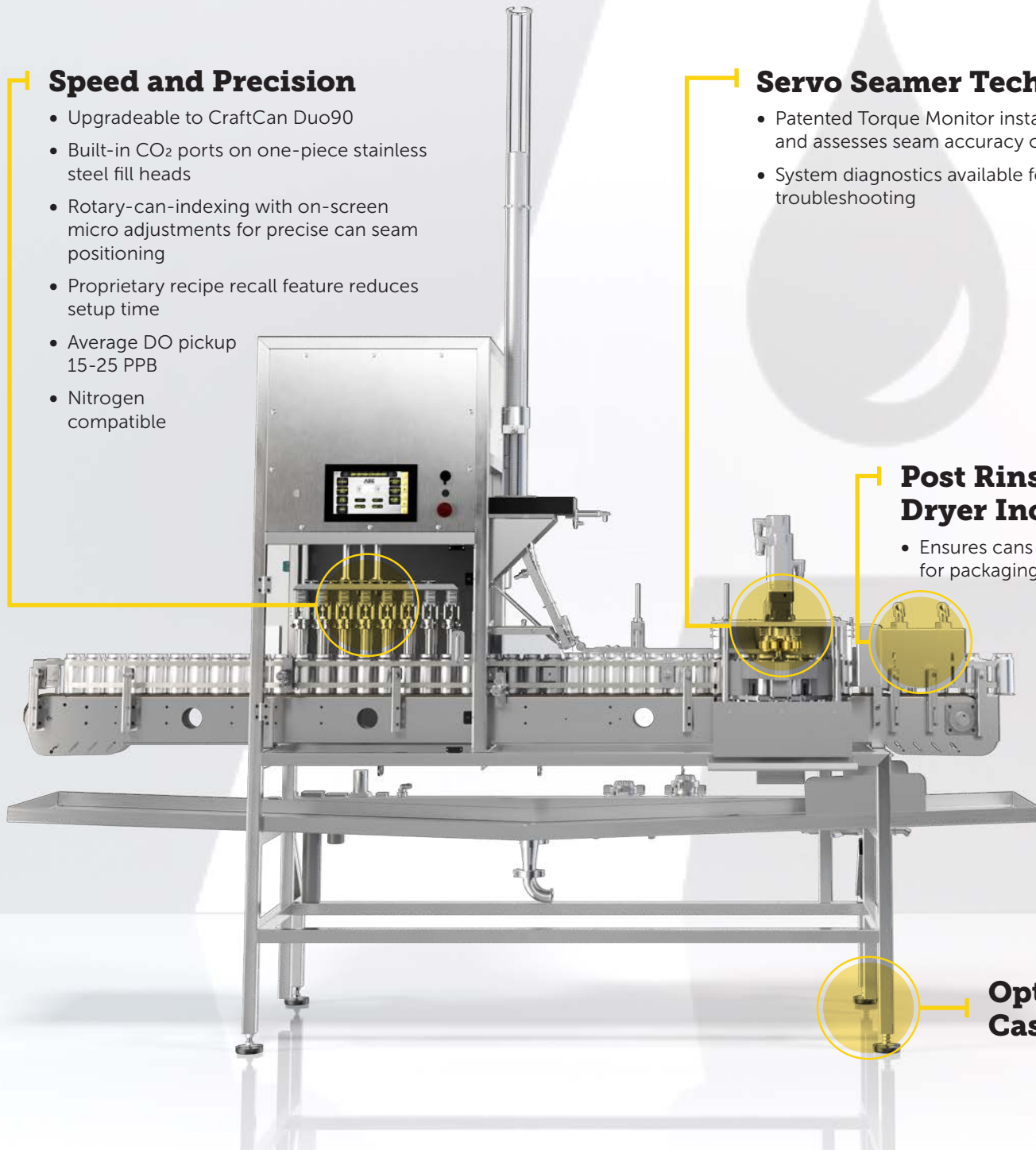

Fills up to 45 Cans Per Minute



CraftCan Duo45

General Specifications

- Up to 45 CPM (based on 12 oz can)
- System dimensions: L: 117" (297 cm), W: 44" (112 cm), H: 83" (211 cm)
- Electrical requirements: 208 V, 60 Hz, 1 phase, 2 wire, 25 A, 20 A (connected load), 4.2 kVA, 3.5 kW average (other electrical options available)
- Air requirements: 1/4" MQC, clean dry/oil-free, 5.75 scfm, 90 psi
- Water Requirements: 3/4" FNPT, filtered city water, 3.0 gpm, 60 psi
- Specifications may vary based on size and customization

Your Complete Package

Each CraftCan Duo45 Canning Line that leaves our facility carries UL certification and an industry-leading five year limited warranty on the metal and welds. In addition to a comprehensive spare parts inventory, you'll receive superior customer support from our team in Lincoln, Nebraska with any ABE purchase.

Compatible Cans/Lids

- Standard US sizes: 12 oz, 16 oz, 19.2 oz (24 oz options available)
- International sizes: 330 ml, 355 ml, 375 ml, 440 ml, 500 ml, 568 ml
- Slim/Sleek: 250 ml slim, 8 oz sleek, 12 oz sleek
- Lids: CDL-E, CDL-W, CDL+, SuperEnd, SuperEndDA+, B64, ISE
- Other sizes available upon request

Compatible Products

- YellowJacket Depalletizer
- Twist Rinse or Z-Rinse
- LabelMax Labeling Systems
- AutoPak Can Carrier
- And More!

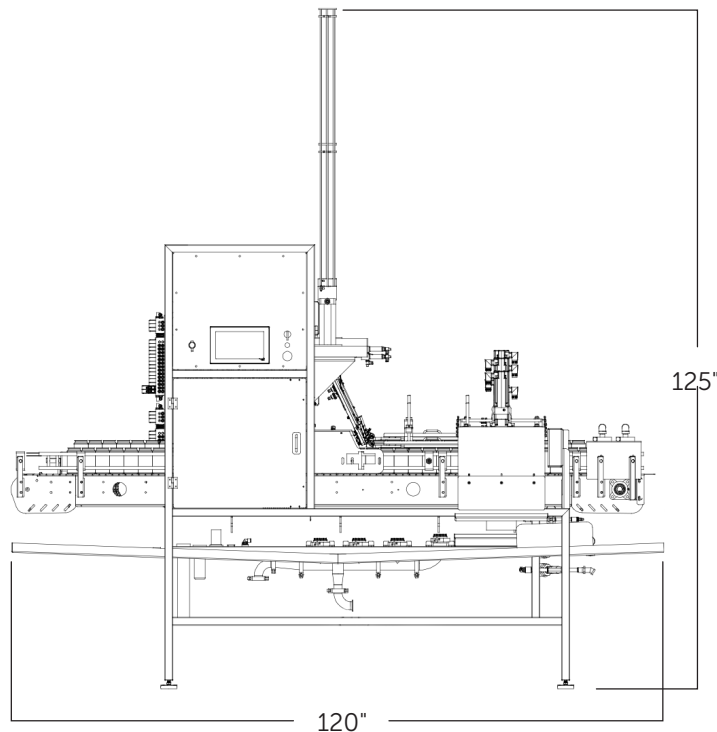

CraftCan Duo90

Yes, you're seeing double. The CraftCan Duo90 features ABE Equipment's proprietary 16-valve, dual-fill design, allowing you to fill two sizes at once! Even at more than twice the speed of the CraftCan35, you won't sacrifice accuracy or reliability. Built with ABE's patented Servo Seamer and on-demand seam analysis, this canning line offers precision filling that is second to none.

Speed and Precision

- Completely independent dual production lanes
- Built-in CO₂ ports on one-piece stainless steel fill heads
- Rotary-can-indexing with on-screen micro-adjustments for precise can seam positioning
- Proprietary recipe recall feature reduces setup time
- Average DO pickup 15-25 PPB
- Nitrogen compatible

Servo Seamer Technology

- Patented Torque Monitor instantly inspects and assesses seam accuracy on every can
- System diagnostics available for remote troubleshooting

Post Rinse & Dryer Included

- Ensures cans are clean & dry for packaging or labeling

Optional Casters

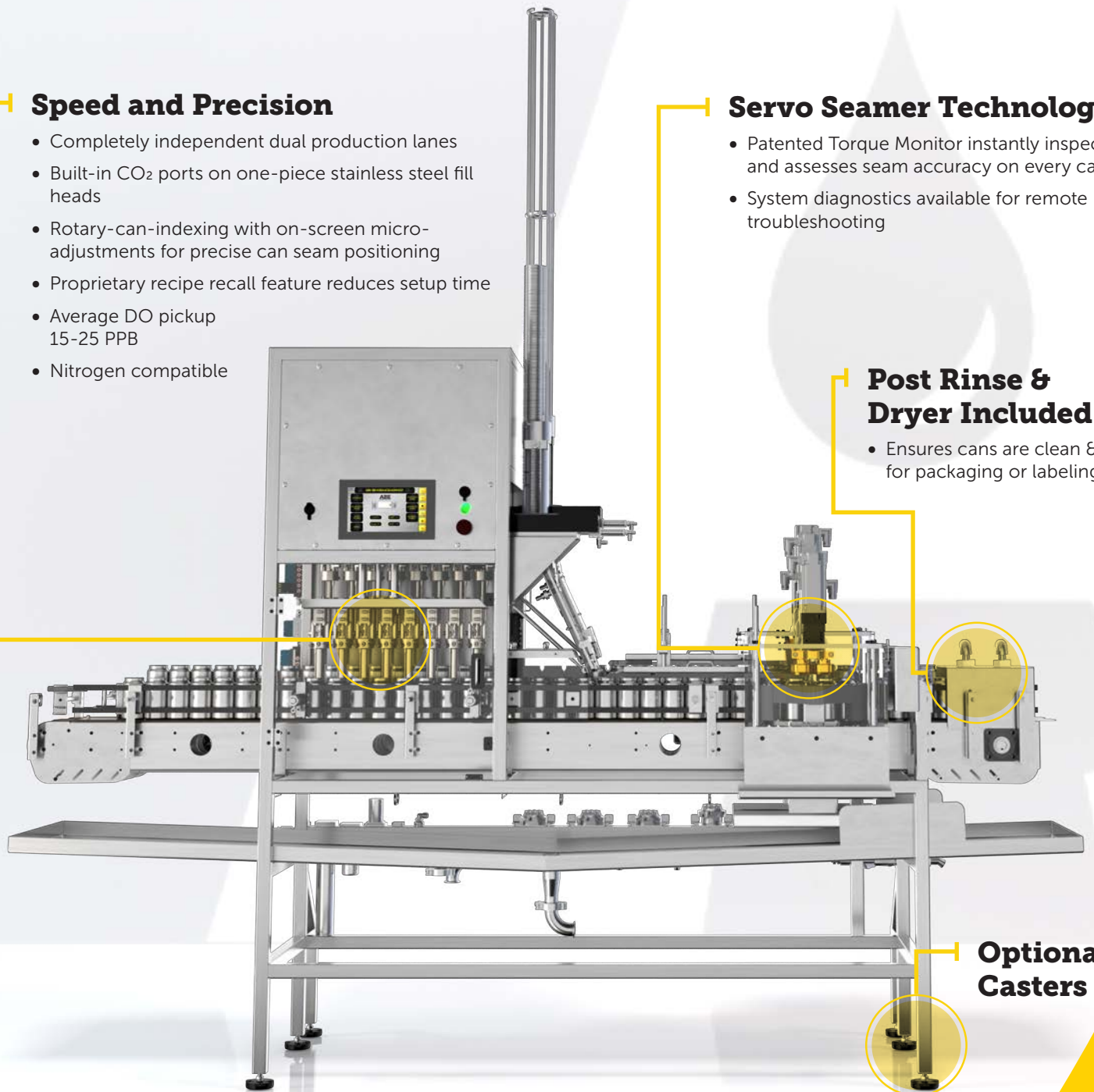

Fills up to 90 Cans Per Minute



CraftCan Duo90

General Specifications

- Up to 90 CPM (based on 12 oz can)
- System dimensions: L: 117" (297 cm), W: 44" (112 cm), H: 83" (211 cm)
- Electrical requirements: 208 V, 60 Hz, 1-Phase, 2 wire, 25 A, 20 A (connected load), 4.2 kVA, 3.5 kW average (other electrical options available)
- UL508A compliant control panel
- Air requirements: 1/2" MQC connection, clean dry CO₂, 5.75 scfm, 100 psi
- Water requirements: 3/4" FNPT connection, filtered city water, 3.0 gpm, 60 psi
- Specifications may vary based on size and customization

Compatible Bottles/Closures

- Standard US Sizes: 12 oz, 16 oz, 19.2 oz (24 oz options available)
- International Sizes: 330 ml, 355 ml, 375 ml, 440 ml, 500 ml, 568 ml
- Slim/Sleek: 250 ml slim, 8 oz sleek, 12 oz sleek
- Lids: CDL-E, CDL-W, CDL+, SuperEnd, SuperEndDA+, B64, ISE
- Other sizes available upon request

Your Complete Package

Each CraftCan Duo90 Canning Line that leaves our facility carries UL certification and an industry-leading five year limited warranty on the metal and welds. In addition to a comprehensive spare parts inventory, you'll receive superior customer support from our team in Lincoln, Nebraska with any ABE purchase.

Compatible Products

- YellowJacket Depalletizer
- Twist Rinse or Z-Rinse
- LabelMax Labeling Systems
- AutoPak Can Carrier
- And More!

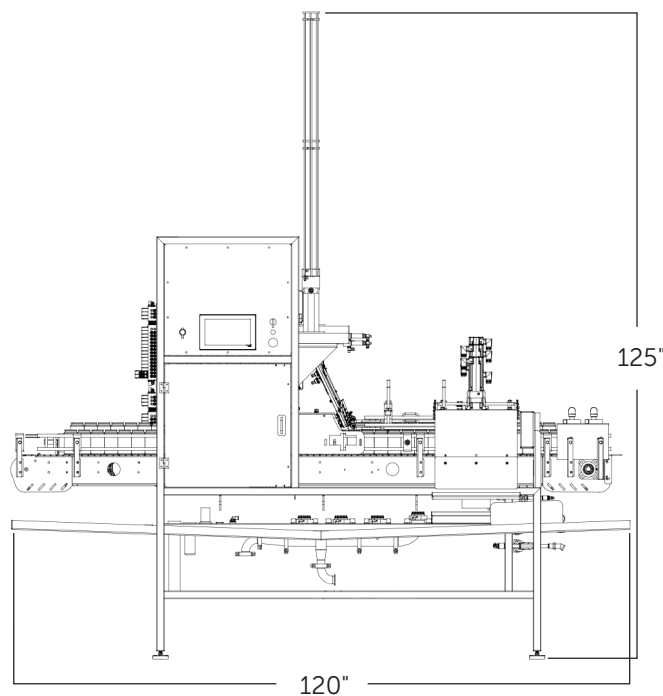

CraftCan Go

The CraftCan Go is a unique and versatile machine that can switch between atmospheric and counter pressure filling. This filling flexibility gives companies the freedom to expand into high-carb beverages without purchasing a new canning line. Its compact design and mobility are additional enhancements that set this unit apart from the competition.

Another advantage of the CraftCan Go is its single-user operation. The physical layout and the infeed/outlet accumulation allows one person to load cans, make adjustments to the HMI, and pack off.

Whether you are packaging a low-carbonated beverage or something with a high volume of CO₂, the CraftCan Go will get the job done.

Precise Counter Pressure Filling

- CO₂ and Nitrogen pre-purge for reliable oxygen evacuation
- External CIP hookup with internal CIP sprayball
- Fills beverages up to 4.0 volumes of CO₂
- Transparent fill drum provides real-time view of product stability
- Easily swapped with the atmospheric fill heads

Precise Atmospheric Filling

- Exclusive one-piece fill head design for enhanced sanitary environment and increased fill level accuracy
- Proprietary CO₂ micro-burst action to better manage foam
- Purge Cycle - precision purge control means reduced dissolved oxygen pickup resulting in reliable oxygen evacuation
- Average DO pickup: 15-25 PPB
- Nitrogen compatible
- Easily swapped with the counter pressure filling unit

Rinse & Seam

- Unique post rinse & dry solution
- Short burst of water while spinning both rinses and dries cans

Included Frame

- Optional casters for increased mobility

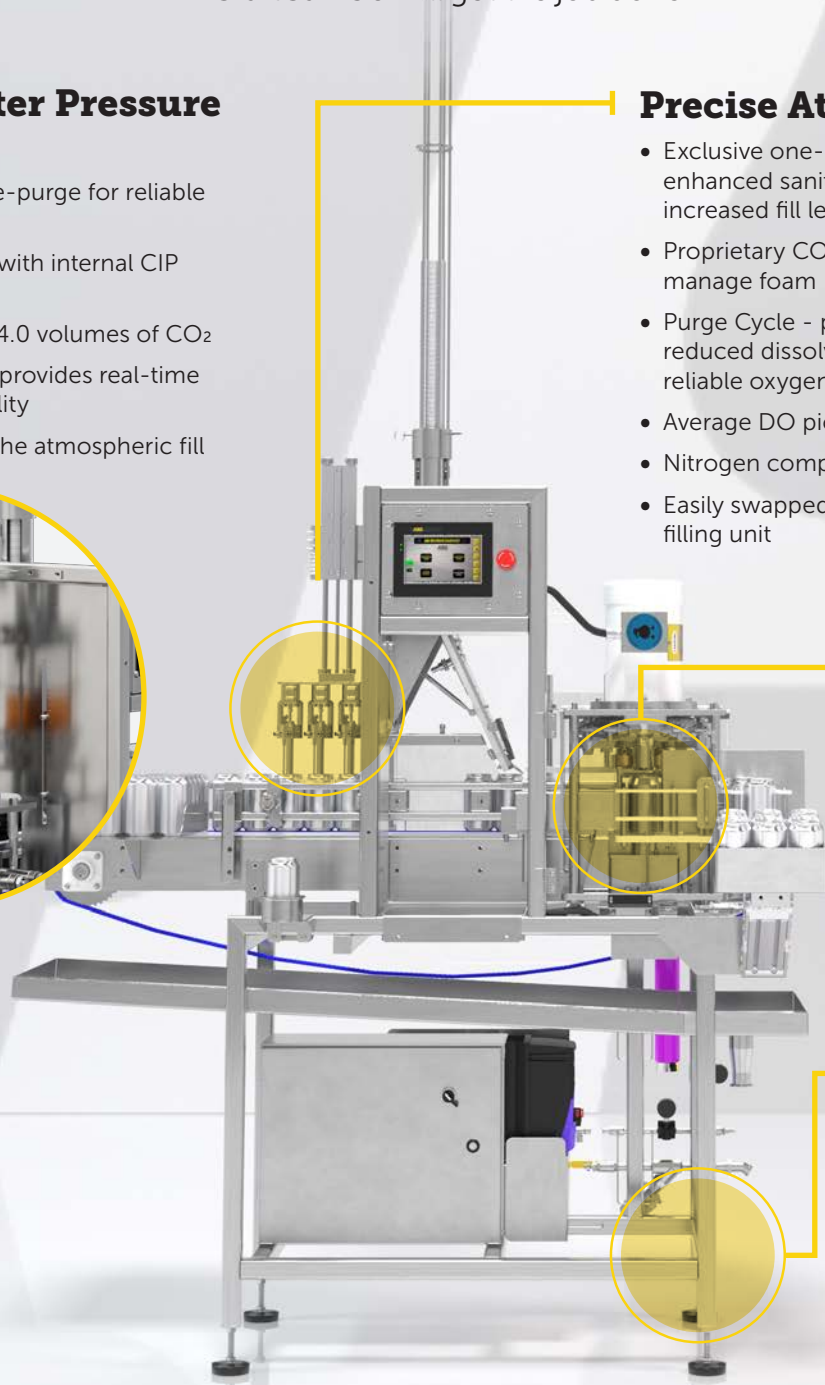

Fills up to 15 CPM Atmospheric or 8 CPM Counter Pressure



CraftCan Go Canning Line

General Specifications

- Atmospheric: Up to 15 CPM (based on 12 oz can)
- Counter-pressure: Up to 8 CPM (based on 12 oz can)
- 64.37" L, 42.35" W, 124.2" H
- 110-120 V, 60 Hz, 12 A

Your Complete Package

Each CraftCan Go Canning Line that leaves our facility carries UL certification and an industry-leading five year limited warranty on the metal and welds. In addition to a comprehensive spare parts inventory, you'll receive superior customer support from our team in Lincoln, Nebraska with any ABE purchase.

Compatible Bottles/Closures

- Standard US sizes: 12 oz, 16 oz, 19.2 oz (24 oz options available)
- International sizes: 330 ml, 355 ml, 375 ml, 440 ml, 500 ml, 568 ml
- Slim/Sleek: 250 ml slim, 8 oz sleek, 12 oz sleek
- Lids: CDL-E, CDL-W, CDL+, SuperEnd, SuperEndDA+, B64, ISE

Compatible Products

- Feed Tables
- TailGator Can Feed System
- Twist Rinse or Z-Rinse
- LabelMax Labeling Systems
- AutoPak Can Carrier

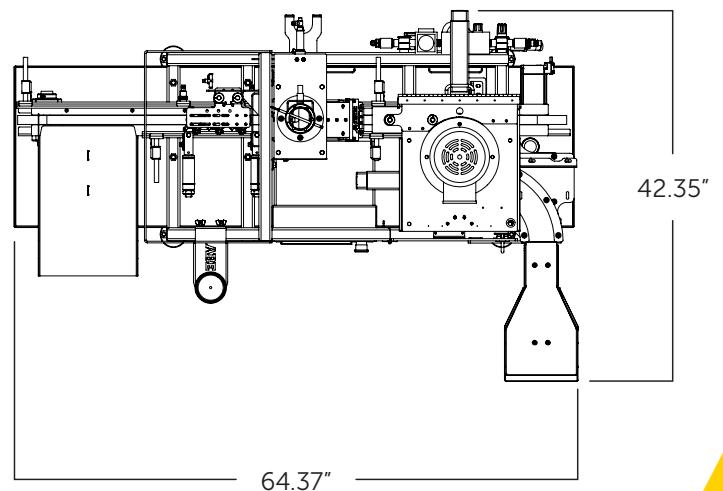
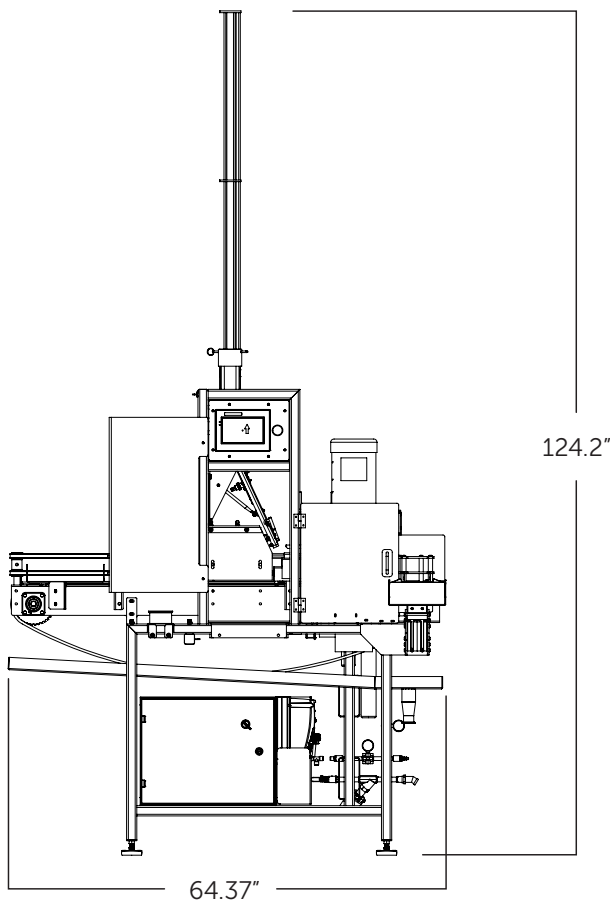

CraftCan Iso16

The CraftCan Iso16 offers innovative, isobaric filling designed with your craft and quality in mind. Counter pressure filling creates an environment for low carbonation loss, and therefore low D.O. levels. From soda, seltzer, and kombucha, to beer and ready-to-drink cocktails, the Iso16 is ready to work. This compact, easily adjustable canner can package a variety of can sizes and beverages of varying CO₂ and LN₂ levels. The Iso16 includes ABE's patented Servo Seamer, providing on-demand seam monitoring and precision filling that is second to none.

Two-Head Counter Pressure Design

- CO₂ and Nitrogen pre-purge for reliable oxygen evacuation
- External CIP hookups with internal CIP sprayballs
- Fills beverages up to 4.0 volumes of CO₂
- Transparent fill drum provides real-time view of product stability

Easy Can Size Changeover

- Raise and lower the entire unit to quickly adjust to various can sizes

PLC Touchscreen Operation

- Fully adjustable cycle times

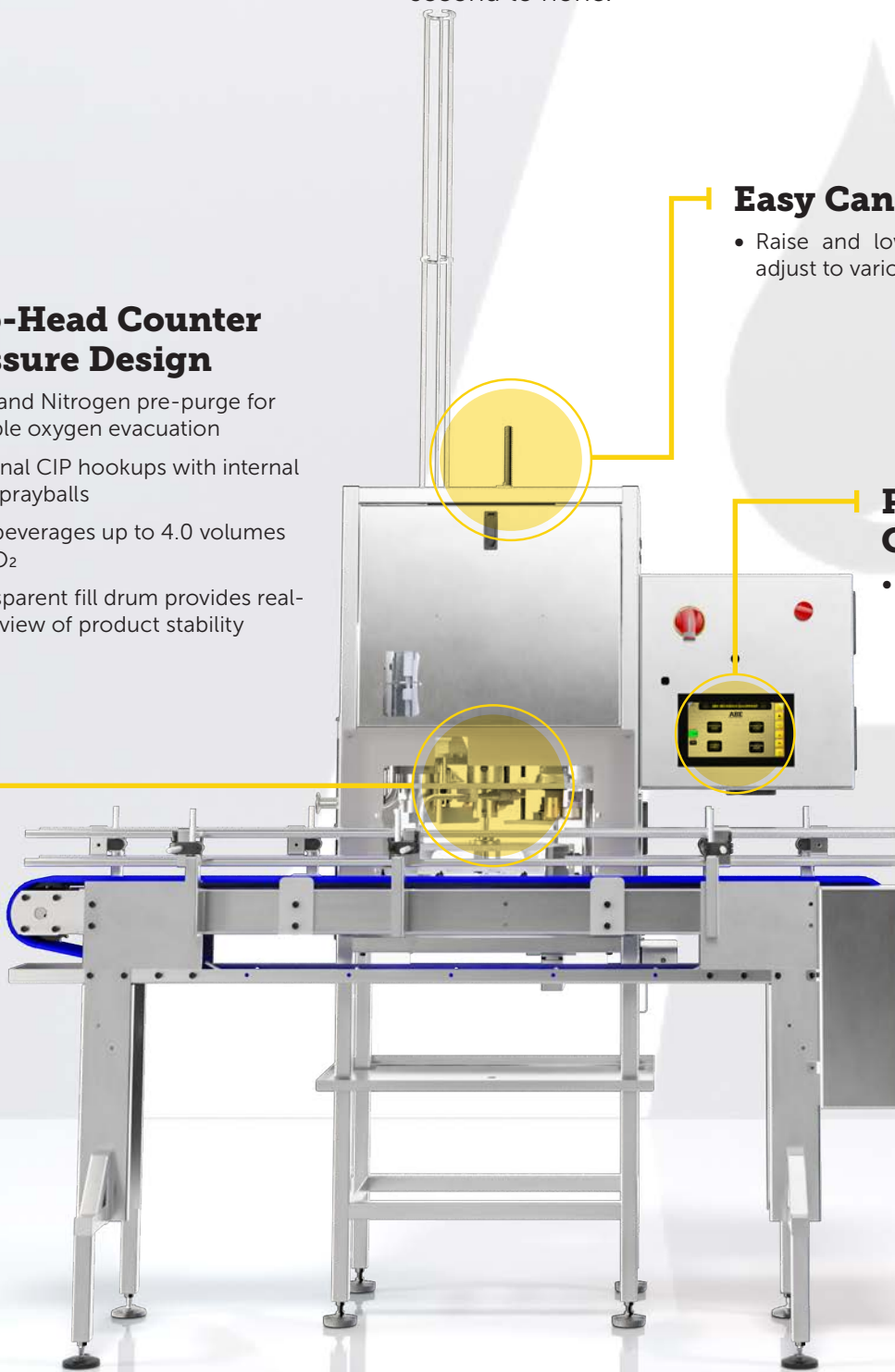

Fills up to 16 Cans Per Minute



CraftCan Iso16

General Specifications

- Up to 16 CPM (based on 12 oz can size)
- 79" L x 26" W x 125" H
- 208 V-240 V, 60 Hz, 17 A

Compatible Bottles/Closures

- Standard US sizes: 12 oz, 16 oz, 19.2 oz (24 oz options available)
- International sizes: 330 ml, 355 ml, 375 ml, 440 ml, 500 ml, 568 ml
- Slim/Sleek: 250 ml slim, 8 oz sleek, 12 oz sleek
- Lids: CDL-E, CDL-W, CDL+, SuperEnd, SuperEndDA+, B64, ISE
- Other sizes available upon request

Your Complete Package

Each Iso16 Canning Line that leaves our facility carries UL certification and an industry-leading five year limited warranty on the metal and welds. In addition to a comprehensive spare parts inventory, you'll receive superior customer support from our team in Lincoln, Nebraska with any ABE purchase.

Compatible Products

- YellowJacket Depalletizer
- TailGator Can Feed System
- Twist Rinse or Z-Rinse
- LabelMax Labeling Systems
- AutoPak Can Carrier
- And More!

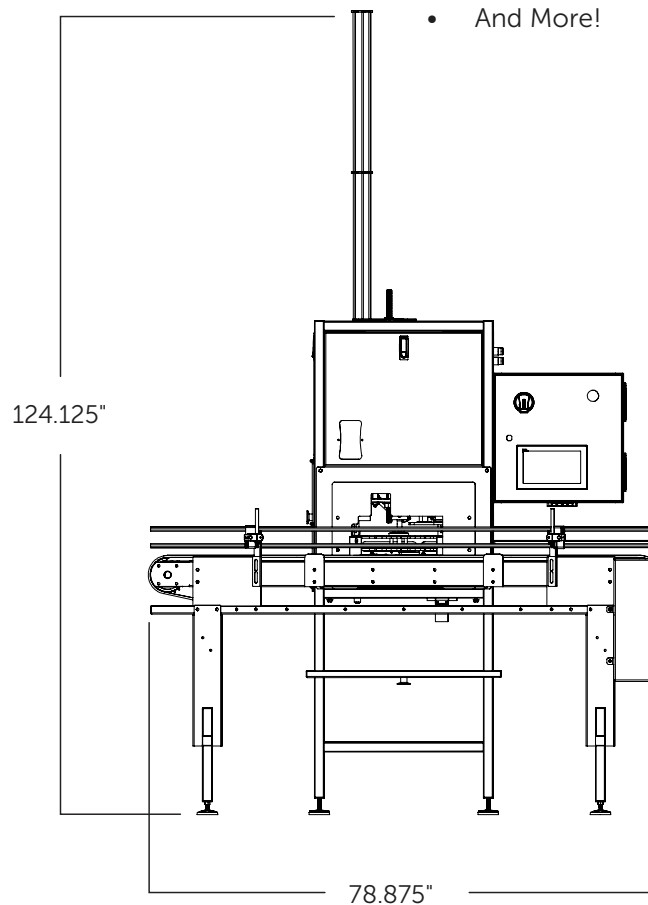

CraftCan Iso40

The CraftCan Iso40 offers innovative, isobaric filling designed with your craft and quality in mind. Counter pressure filling creates an environment for low carbonation loss, and therefore low D.O. levels. From soda, seltzer, and kombucha, to beer and ready-to-drink cocktails, the Iso40 is ready to work. This compact, easily adjustable canner can package a variety of can sizes and beverages of varying CO₂ or LN₂ levels. The Iso40 includes ABE's patented Servo Seamer, providing on-demand seam monitoring and precision filling that is second to none.

Six Head Counter Pressure Design

- Cans are purged, filled, and seamed in-line
- Easy can height and diameter adjustments
- Fill Beverages up to 4.0 volumes of CO₂
- CIP compatible with pre-programmed instructions

PLC Touchscreen Operation

- Fully adjustable cycle times
- Average DO Pickup 10-25 PPB

Servo Seamer Technology

- Patent pending Torque Monitor instantly inspects and assesses seam accuracy on every can
- System diagnostics available for remote troubleshooting

Post Rinse & Dryer Included

- Ensures cans are clean & dry for packaging or labeling

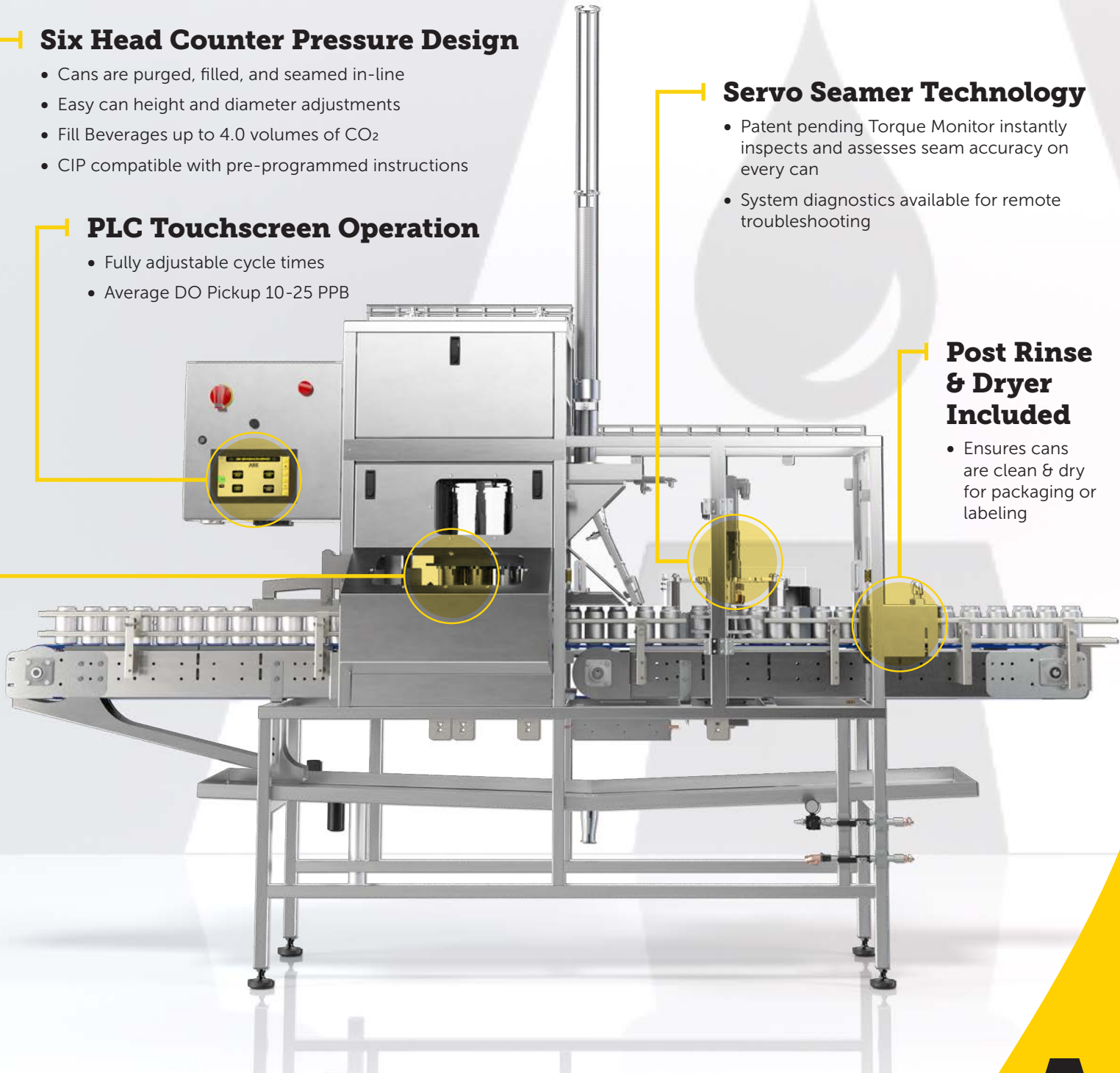

Fills up to 40 Cans Per Minute



CraftCan Iso40

General Specifications

- Up to 40 CPM (based on 12 oz can size)
- 140" L, 42" W, 125" H
- 208 V-240 V, 60 Hz, 17 A

Compatible Bottles/Closures

- Standard US sizes: 12 oz, 16 oz, 19.2 oz (24 oz options available)
- International sizes: 330 ml, 355 ml, 375 ml, 440 ml, 500 ml, 568 ml
- Slim/Sleek: 250 ml slim, 8 oz sleek, 12 oz sleek
- Lids: CDL-E, CDL-W, CDL+, SuperEnd, SuperEndDA+, B64, ISE
- Other sizes available upon request

Your Complete Package

Each Iso40 Canning Line that leaves our facility carries UL certification and an industry-leading five year limited warranty on the metal and welds. In addition to a comprehensive spare parts inventory, you'll receive superior customer support from our team in Lincoln, Nebraska with any ABE purchase.

Compatible Products

- YellowJacket Depalletizer
- TailGator Can Feed System
- Twist Rinse or Z-Rinse
- LabelMax Labeling Systems
- AutoPak Can Carrier
- And More!

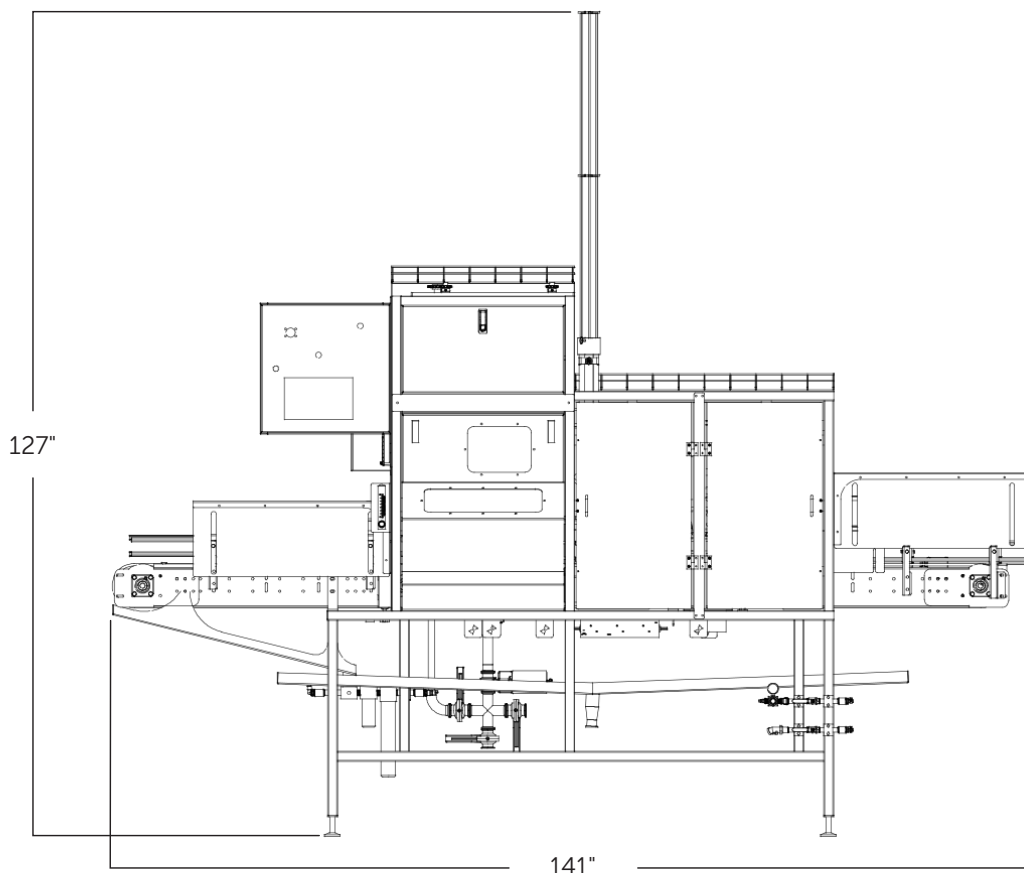

30+ YEARS OF EXPERIENCE
130,000+ SQUARE FEET
130+ EMPLOYEES



ABE CAMPUS
Lincoln, NE, USA

About ABE Equipment

You need reliable equipment to produce and package your craft beverage, and a knowledgeable team to support you and your investment. ABE Equipment offers complete equipment solutions to produce and package your beverages, and unwavering customer support for the life of your equipment.

Our tenured sales team will help you determine your equipment needs and work through everything that you need to start or to expand your business. You will work with our engineers to determine any customization to best fit your needs and your space. We guide you through the entire process with layout and engineering services from degreed engineers, and startup and training and support from our experienced customer service team. Let us handle your equipment solution so that you can focus on your craft.

ABE
EQUIPMENT

ABE Equipment
2001 SW 6th St.
Lincoln, NE 68522

402.475.2337
info@abeequipment.com

REQUEST A QUOTE
ABEquipment.com

Your Craft. Our Passion.