

CIP Cart

ABE
EQUIPMENT

In 1748, Founding Father Benjamin Franklin famously stated: "Time is money". While he didn't have an ABE Equipment Dual Tank 150 Liter CIP System in mind when he said that, we think he was spot on. The ABE portable Dual Tank 150 Liter CIP System recovers chemicals and keeps them at the right temperature, saving you hundreds of dollars. Don't waste time and energy dragging long hoses from tank to tank, when you can simply wheel the ABE Equipment CIP System to each tank.

Mobile & Easy to Use

- System mounted on wheeled cart
- Automatic temperature control
- Sanitary stainless steel head, inlet, and outlet

Reduce Labor & Resources

- Dual 40 gallon (150 liter) tanks
- Independent reservoir temperature controls
- Sight tubes on each reservoir for easy water/chemical measurements
- A complete CIP system



ABE
EQUIPMENT

2001 SW 6th Street | Lincoln, NE 68522 | (402) 475-2337 | ABEEquipment.com

CIP Cart

General Specifications

- System dimensions:
 - Length: 43.75 in (111 cm)
 - Width: 58.5 in (148.6 cm)
 - Height: 53.8 in (136.5 cm)
- Electrical requirements: 208-240 volt, 3-phase, 60 Hz, 50 Amp (other electrical options available)

Additional Features

- UL rated
- Single phase option available
- 1 hp washdown pump

Your Complete Package

Each CIP Cart that leaves our facility carries UL certification and an industry-leading five year limited warranty on the metal and welds. In addition to a comprehensive spare parts inventory, you'll receive superior customer support from our team in Lincoln, Nebraska with any ABE purchase.

Related Products

- ABE Brewhouses & Tanks
- ABE CraftCan Canning Lines
- Keg Commander Keg Washer

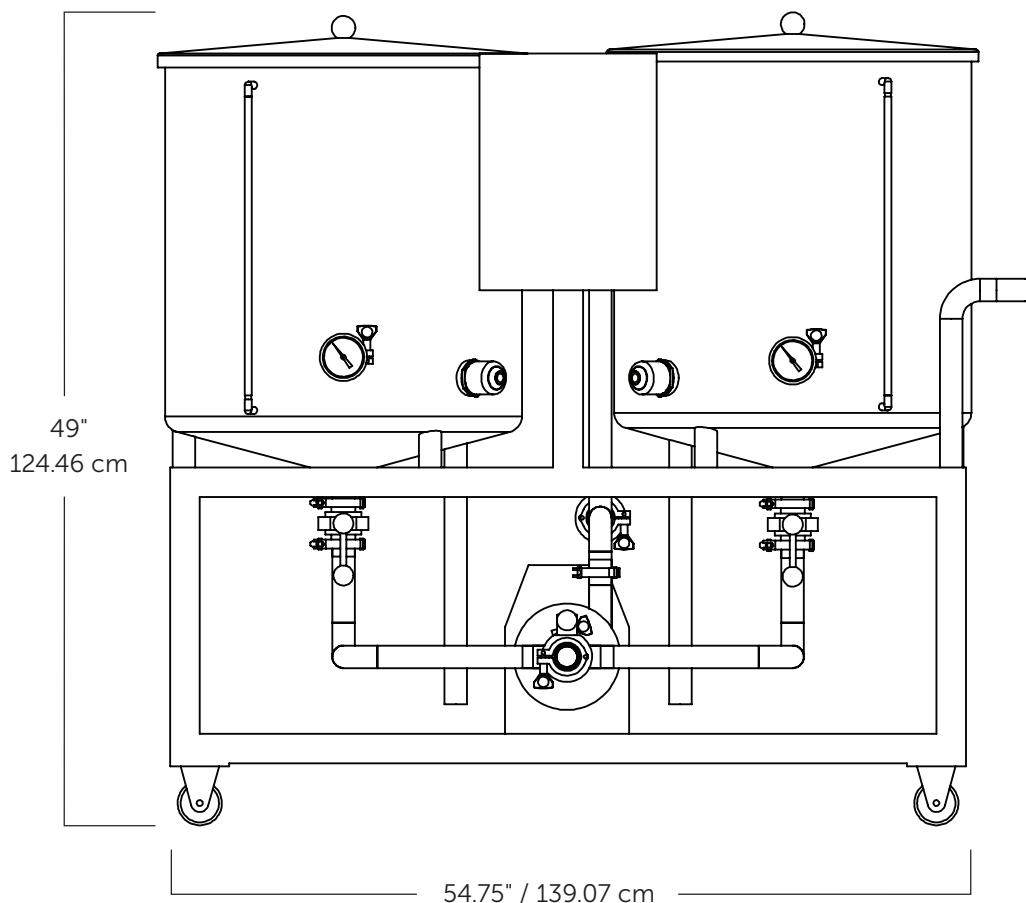

ABE Equipment reserves the right to change specification without notice. All specifications are approximate. ©2022 ABE Equipment