

CraftCan15 Canning Line

ABE
EQUIPMENT

The CraftCan15 is designed to fill, lid and seam up to 15 cans per minute in a wide variety of aluminum cans with minimal downtime and maximum throughput. Engineered with our patented Servo Seamer and on-demand seam analysis, this line offers precision filling that is second to none. The CraftCan15 is innovative, versatile, and affordable; built to generate the profits your craft beverage deserves.

Precision Filling

- Exclusive one-piece fill head design for enhanced sanitary environment and increased fill level accuracy
- Proprietary CO₂ micro-burst action to better manage foam
- Purge Cycle - precision purge control means reduced dissolved oxygen pickup resulting in reliable oxygen evacuation
- Upgradeable to CraftCan35
- Average DO pickup: 15-25 PPB
- Nitrogen compatible

Quick-Change Lid Magazine

- Increase your efficiency

Servo Seamer Technology

- Patented Torque Monitor instantly inspects and assesses seam accuracy on every can
- System diagnostics available for remote troubleshooting

Post Rinse & Dryer Included

- Ensures cans are clean & dry for packaging or labeling

Small Footprint

- 8' length x 2' width fits in tight spaces
- Optional casters

Fills up to 15 Cans Per Minute

ABE
EQUIPMENT

2001 SW 6th Street | Lincoln, NE 68522 | (402) 475-2337 | ABEEquipment.com

CraftCan15 Canning Line

General Specifications

- Up to 15 CPM (based on 12 oz can)
- Electrical requirements: 208 V, 60 Hz, 1-Phase, 2 wire, 20 A, 12 A (connected load), 2.5 kVA, 2.1 kW average (other electrical options available)
- UL508A compliant control panel
- Water Requirements: 2 gpm @ 60 psi
- Air Requirements: 5 SCFM @ 100 psi
- Specifications may vary based on size and customization

Your Complete Package

Each CraftCan15 Canning Line that leaves our facility carries UL certification and an industry-leading five year limited warranty on the metal and welds. In addition to a comprehensive spare parts inventory, you'll receive superior customer support from our team in Lincoln, Nebraska with any ABE purchase.

Compatible Cans/Lids

- Standard US sizes: 12 oz, 16 oz, 19.2 oz (24 oz options available)
- International sizes: 330 ml, 355 ml, 375 ml, 440 ml, 500 ml, 568 ml
- Slim/Sleek: 250 ml slim, 8 oz sleek, 12 oz sleek
- Lids: CDL-E, CDL-W, CDL+, SuperEnd, SuperEndDA+, B64, ISE
- Other sizes available upon request

Compatible Products

- YellowJacket Depalletizer
- Twist Rinse or Z-Rinse
- LabelMax Labeling Systems
- AutoPak Can Carrier
- And More!

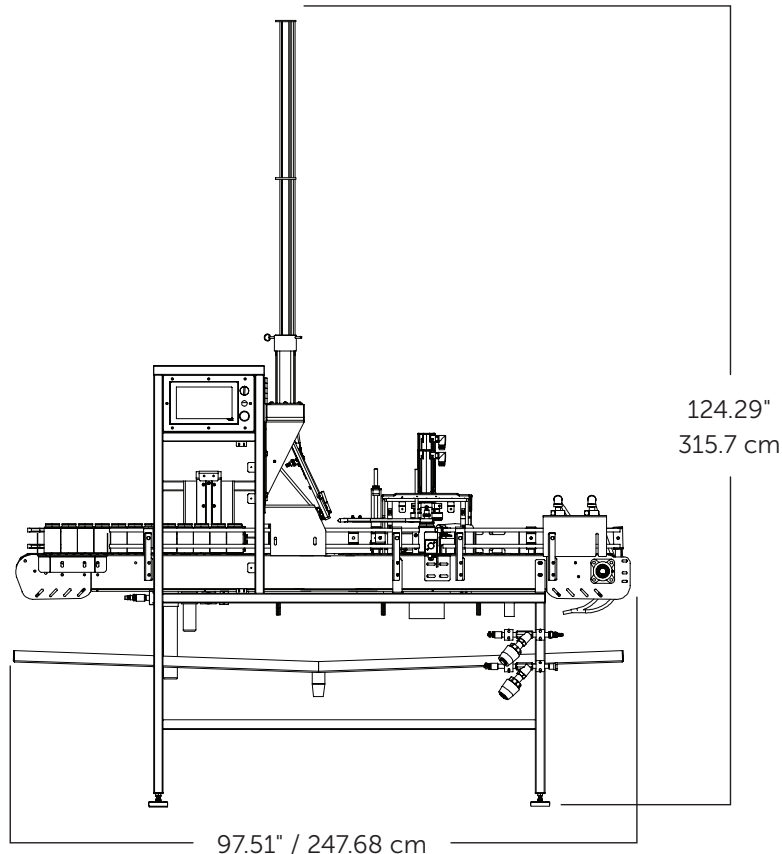

ABE Equipment reserves the right to change specification without notice. All specifications are approximate. ©2024 ABE Equipment