

# CraftCan Go Canning Line

**ABE**  
EQUIPMENT

The CraftCan Go is the only machine in its class that can switch between atmospheric and counter pressure filling. This filling flexibility gives companies the freedom to expand into high-carb beverages without purchasing a new canning line. Its compact design and mobility are additional enhancements that set this unit apart from the competition.

Another advantage of the CraftCan Go is its single-user operation. The physical layout and the infeed/outlet accumulation allows one person to load cans, make adjustments to the HMI, and pack off. Whether you are packaging a low-carbonated beverage or something with a high volume of CO<sub>2</sub>, the CraftCan Go will get the job done.

## Precise Counter Pressure Filling

- CO<sub>2</sub> and Nitrogen pre-purge for reliable oxygen evacuation
- External CIP hookup with internal CIP sprayball
- Fills beverages up to 4.0 volumes of CO<sub>2</sub>
- Transparent fill drum provides real-time view of product stability
- Easily swapped with the atmospheric fill head

## Precise Atmospheric Filling

- Exclusive one-piece fill head design for enhanced sanitary environment and increased fill level accuracy
- Proprietary CO<sub>2</sub> micro-burst action to better manage foam
- Purge Cycle - precision purge control means reduced dissolved oxygen pickup resulting in reliable oxygen evacuation
- Average DO pickup: 15-25 PPB
- Nitrogen compatible
- Easily swapped with the counter pressure filling unit
- Compatible with kegs

## Rinse & Seam

- Unique post rinse & dry solution to minimize compressed air and water usage
- Short burst of water while spinning both rinses and dries cans

## Included Frame

- Optional casters for increased mobility

**Fills up to 15 CPM Atmospheric or 10 CPM Counter Pressure**

**ABE**  
EQUIPMENT

2001 SW 6th Street | Lincoln, NE 68522 | (402) 475-2337 | ABEequipment.com

# CraftCan Go Canning Line

## General Specifications

- Atmospheric: Up to 15 CPM (based on 12 oz can)
- Counter pressure: Up to 10 CPM (based on 12 oz can)
- 64.37" L, 42.35" W, 124.2" H
- 110-120 V, 60 Hz, 12 A
- Other voltages available

## Your Complete Package

Each CraftCan Go Canning Line that leaves our facility carries UL certification and an industry-leading five year limited warranty on the metal and welds. In addition to a comprehensive spare parts inventory, you'll receive superior customer support from our team in Lincoln, Nebraska with any ABE purchase.

## Compatible Cans/Lids

- Standard US sizes: 12 oz, 16 oz, 19.2 oz (Ask about 24 oz options)
- International sizes: 330 ml, 355 ml, 375 ml, 440 ml, 500 ml, 568 ml
- Slim/Sleek: 250 ml slim, 8 oz sleek, 12 oz sleek
- Lids: CDL-E, CDL-W, CDL+, SuperEnd, SuperEndDA+, B64, ISE

## Compatible Products

- Feed Tables
- TailGator Can Feed System
- Twist Rinse or Z-Rinse
- LabelMax Labeling Systems
- AutoPak Can Carrier

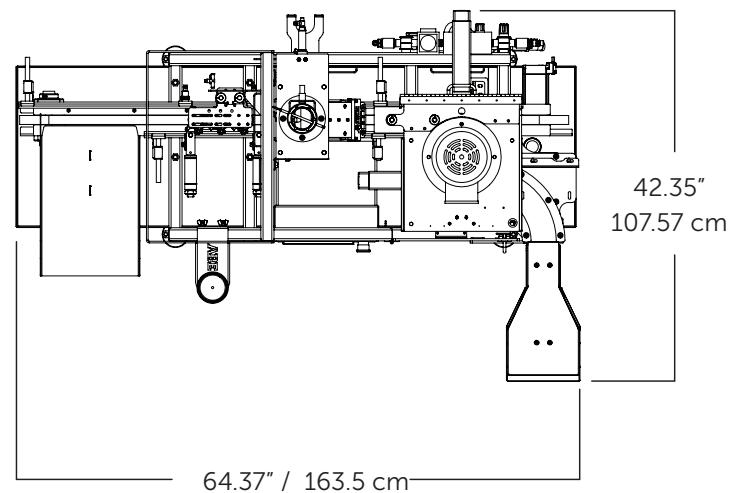
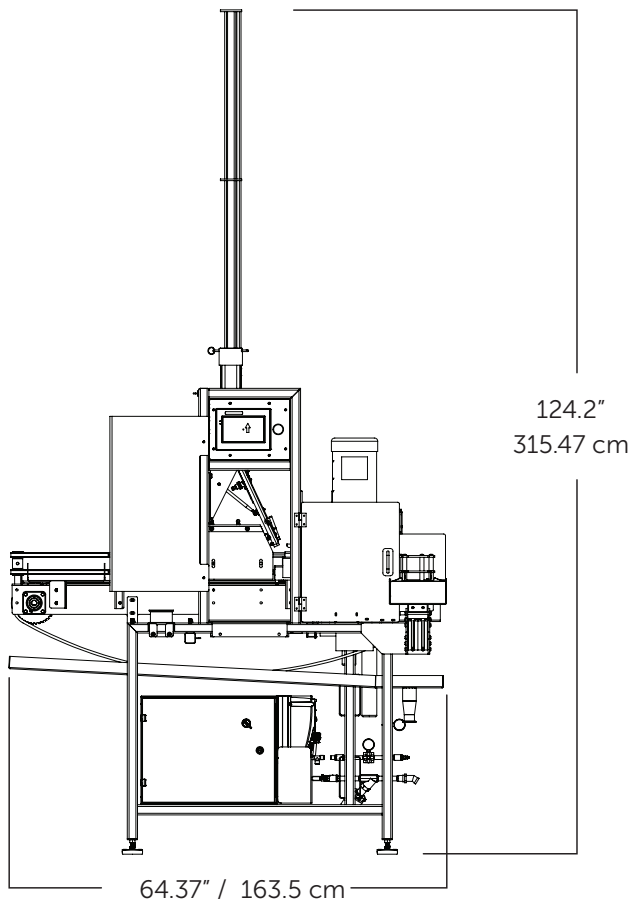

ABE Equipment reserves the right to change specification without notice. All specifications are approximate. ©2022 ABE Equipment