

Barrel Cask-It

ABE
EQUIPMENT

ABE's Barrel Cask-It is designed to eliminate the labor and often cumbersome chore of emptying whiskey, wine, or any other spirit barrel. With its solid stainless steel frame and top-mounted rollers for easy barrel rotation, we've taken all the guess work out of emptying your barrels. Simply set your full barrel atop the adjustable rollers and rotate your barrel, allowing its contents to discharge through a false bottom and out to the drain. The top-mounted rollers can be positioned in multiple locations, accomodating a wide range of barrel sizes and positions. Don't get buried in labor emptying barrels; rest in peace knowing you have the ABE Barrel Cask-It to take care of you.

Easy Emptying

- Top-mounted rollers for easy barrel rotation
- Rollers can be placed in multiple locations, accomodating various barrel sizes

Sturdy Construction

- Stainless Steel frame
- False bottom to catch barrel debris prior to exiting drain
- Sloped bottom allows all contents to flow to drain

Adaptable

- Unit comes standard with casters for easy mobility
- Barrels can be placed parallel or perpedicular depending on bung location



ABE
EQUIPMENT

2001 SW 6th Street | Lincoln, NE 68522 | (402) 475-2337 | ABEEquipment.com

Barrel Cask-It

General Specifications

- 115 Gallon total volume
- 87 Gallon volume below false bottom
- 1.5" Sanitary drain
- Can accomodate a variety of barrels and bung locations

Compatible Products

- Patriot Fill Station
- Filter housing
- Brite and Fermentation Tanks

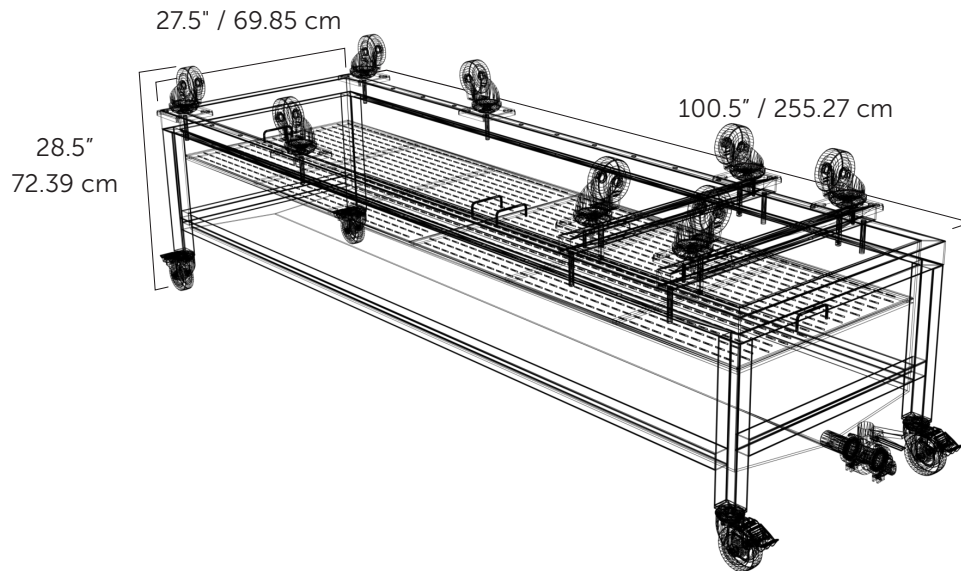

30+ YEARS OF EXPERIENCE
130,000+ SQUARE FEET
130+ EMPLOYEES



ABE CAMPUS
Lincoln, NE, USA

ABE Equipment reserves the right to change specification without notice. All specifications are approximate. ©2024 ABE Equipment