

KegCommander

Dirty kegs? Clean them with the KegCommander Keg Washer by ABE Equipment. This dual-head system cleans and purges up to 34 kegs per hour and is compatible with most standard couplings (A, S, D & U). The independently adjustable cleaning heads allow you to clean different sized kegs simultaneously. The process can be controlled with the HMI touchscreen interface, increasing or decreasing the length of each of the 21 steps in the cleaning cycle. This durable machine is constructed of 304 stainless steel, including the piping, and has two separate heated liquid holding tanks to ensure a thorough reserve for the entire cleaning process. When the mission calls for speed and spotless results, the fully automated dual-head KegCommander Keg Washer is built for the task.

Easy and Efficient

- Once started, the system can be left unattended until cycle is complete
- Low liquid sensors in each tank protect heaters and pumps
- Keg holders are independently adjustable to clean different sizes simultaneously
- 21-step cleaning process with adjustable step timing
- Independent temperature controls for each solution tank
- No manual keg coupling

6-inch Color Touchscreen



Dual Head Keg Washer

- Stainless steel construction including piping
- Compatible with standard couplings (A, S, D, and U)
- Designed and assembled in the USA

KegCommander

General Specifications

- Speed: 34 Kegs per hour
- Dimensions: Length: 47 in (119.4 cm), Width: 51.5 in (130.8 cm), Height: 78 in - 80.5 in (198 cm - 204.5 cm)
- Electrical requirements: 208-240 volt, 3-phase, 35 Amp (other electrical options available)
- Water requirements: 15 GPM, 50 PSI
- Air requirement for compressed: 17 CFM @ 90 PSI
- Air requirement for CO₂: 17 CFM @ 90 PSI

Your Complete Package

Each KegCommander that leaves our facility carries UL certification and an industry-leading five year limited warranty on the metal and welds. In addition to a comprehensive spare parts inventory, you'll receive superior customer support from our team in Lincoln, Nebraska with any ABE purchase.

Related Products

- ABE Brewhouses & Tanks
- ABE CraftCan Canning Lines
- CIP Cart
- Nitrogen Purge

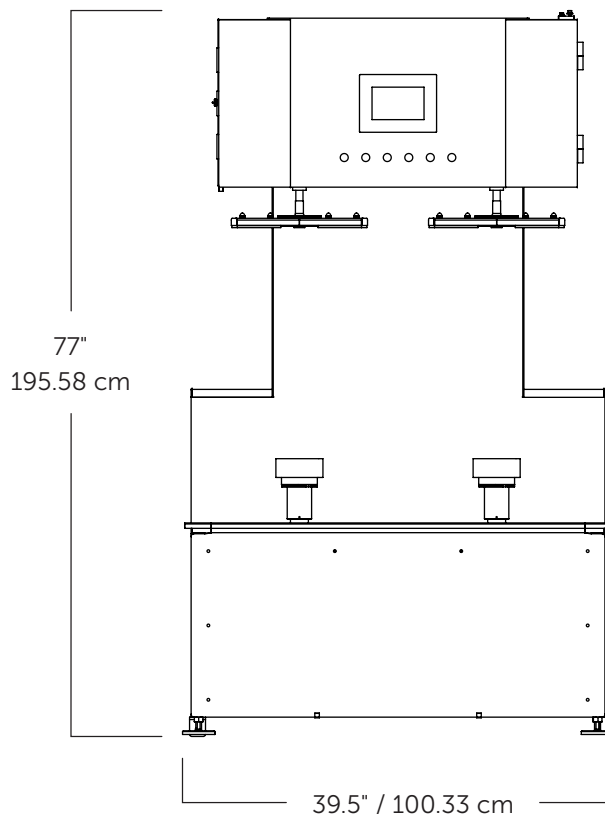

ABE Equipment reserves the right to change specification without notice. All specifications are approximate. ©2024 ABE Equipment