

# LabelMax35

**ABE**  
EQUIPMENT

The LabelMax35 tabletop labeler is a compact and economically-priced label applicator that is ideal for production rates of up to 35 containers per minute. The LabelMax35 features a Programmable Logic Controller (PLC) that manages specific functions of the operation. The computerized controls are simple and dependable, and allow the operator to match speeds of the labeler to the pre-set conveyor speed. Optical sensors ensure smooth and trouble-free operation. The touchscreen Front Panel Display provides real-time information on the labeling process. The unit's simplicity makes it ideal for packaging lines requiring frequent changeovers on a wide variety of products.

## Premium Features

- Touch screen panel for ease of operation and continual visual monitoring
- Designed to print date/batch code directly onto label prior to application
- Built-in photo sensor and AUX port for optional external photo sensor
- Optional date coder

## Fast, Accurate Labeling

- Servo motor for precise positioning
- Auto-wrap speed syncs to label speed; no manual adjustment needed
- Spacer wheel included for optimal package spacing

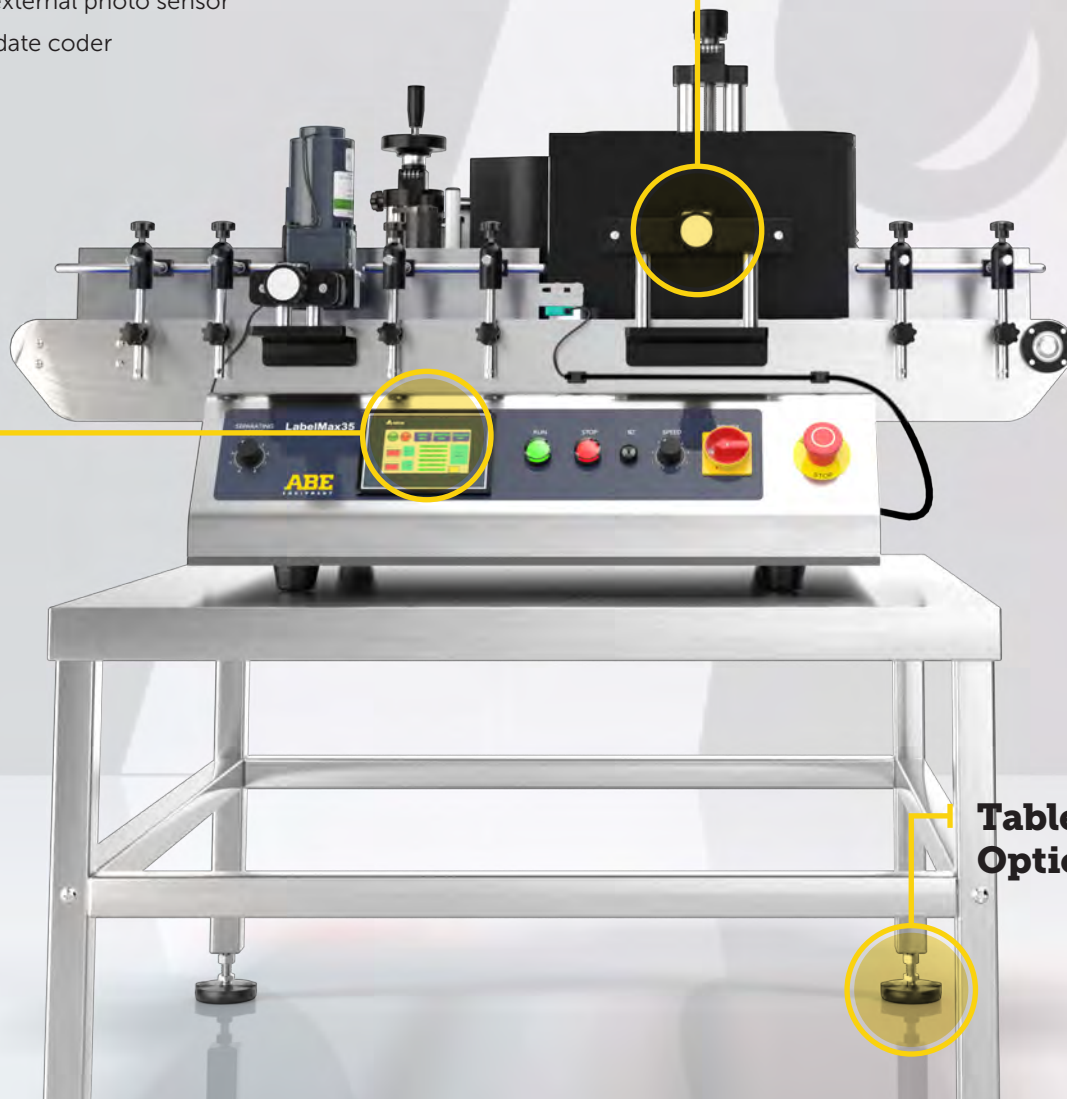

## Table and Casters Optional

**ABE**  
EQUIPMENT

2001 SW 6th Street | Lincoln, NE 68522 | (402) 475-2337 | [ABEEquipment.com](http://ABEEquipment.com)

# LabelMax35

## Specifications

- Face Stock: Non-Transparent
- Spool diameter: 11.8" (300 mm)
- Inner core: 3" (76 mm)
- 220 volt 50/60 Hz
- Net weight: 100 Kg

## Additional Specs

- Maximum Label Width: 5.9" (149.86 mm)
- Minimum Label Width: 2.5" (63.5 mm)
- Maximum Label Length: 11.75" (298.45 mm)
- Minimum Label Length: 2.5" (63.5 mm)
- Maximum Spool Diameter: 11.5" (292.1 mm)

## Your Complete Package

Each LabelMax35 that leaves our facility carries UL certification and an industry-leading five year limited warranty on the metal and welds. In addition to a comprehensive spare parts inventory, you'll receive superior customer support from our team in Lincoln, Nebraska with any ABE purchase.

## Compatible Products

- TruPatriot Bottle Filler
- CraftCan Canning Systems
- Autopak Can Carrier Applicator

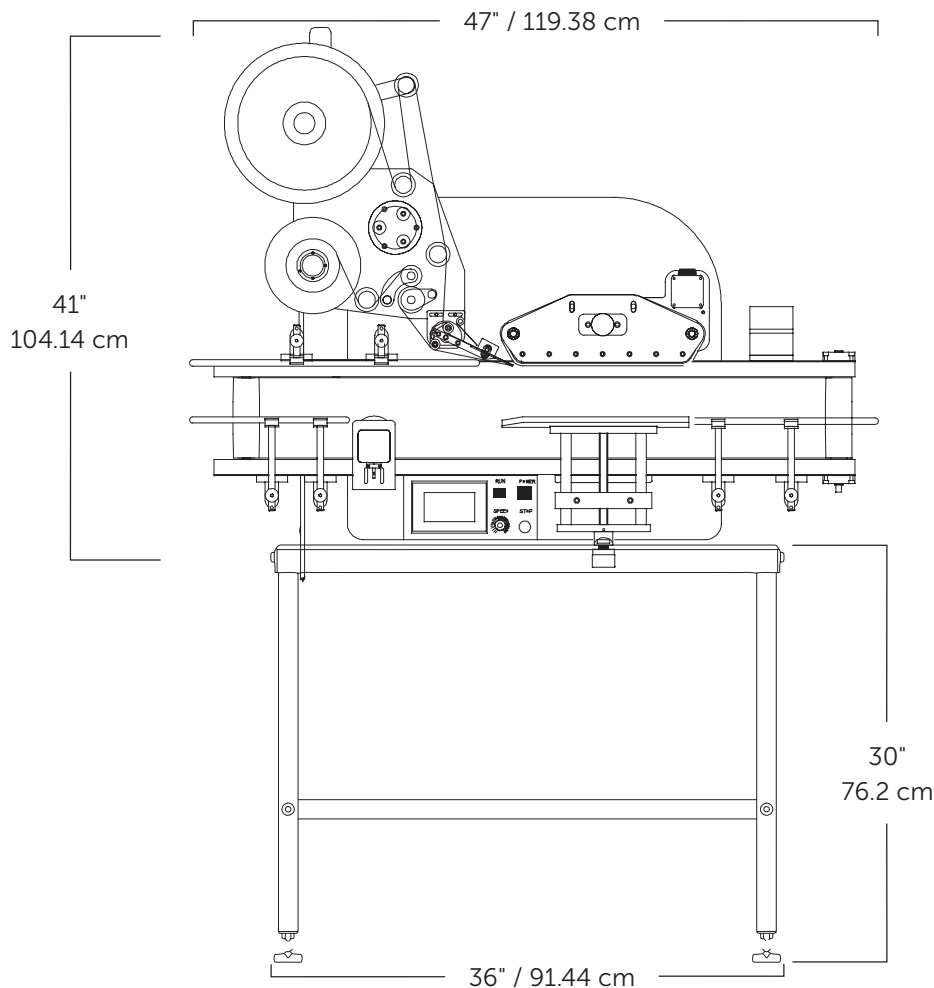

ABE Equipment reserves the right to change specification without notice. All specifications are approximate. ©2024 ABE Equipment