

# Pilot Skid

**ABE**  
EQUIPMENT

ABE Equipment has developed a simple way for startup craft distiller pioneers to establish a small-scale distillery without spending a vast amount of money. Whiskey, vodka, gin, and other clear spirits can be produced utilizing this still. Depending on your production needs, additional options include a rectifying column, whiskey helmet, or spirits safe.

## Small Footprint

- Skid mounted
- 50 gallon still, spirit safe, and 3 x 100 gallon fermentation tanks

## Premium Components

- Copper column, dephlegmator, & final condenser
- Two 5Kw C1D1 Compliant heating elements
- 200 liter insulated stainless steel kettle

## Spirits Safe

- 304 stainless steel spirit safe simplifies the separation of your heads, hearts, and tails
- Rotating parrot
- Lockable cabinet

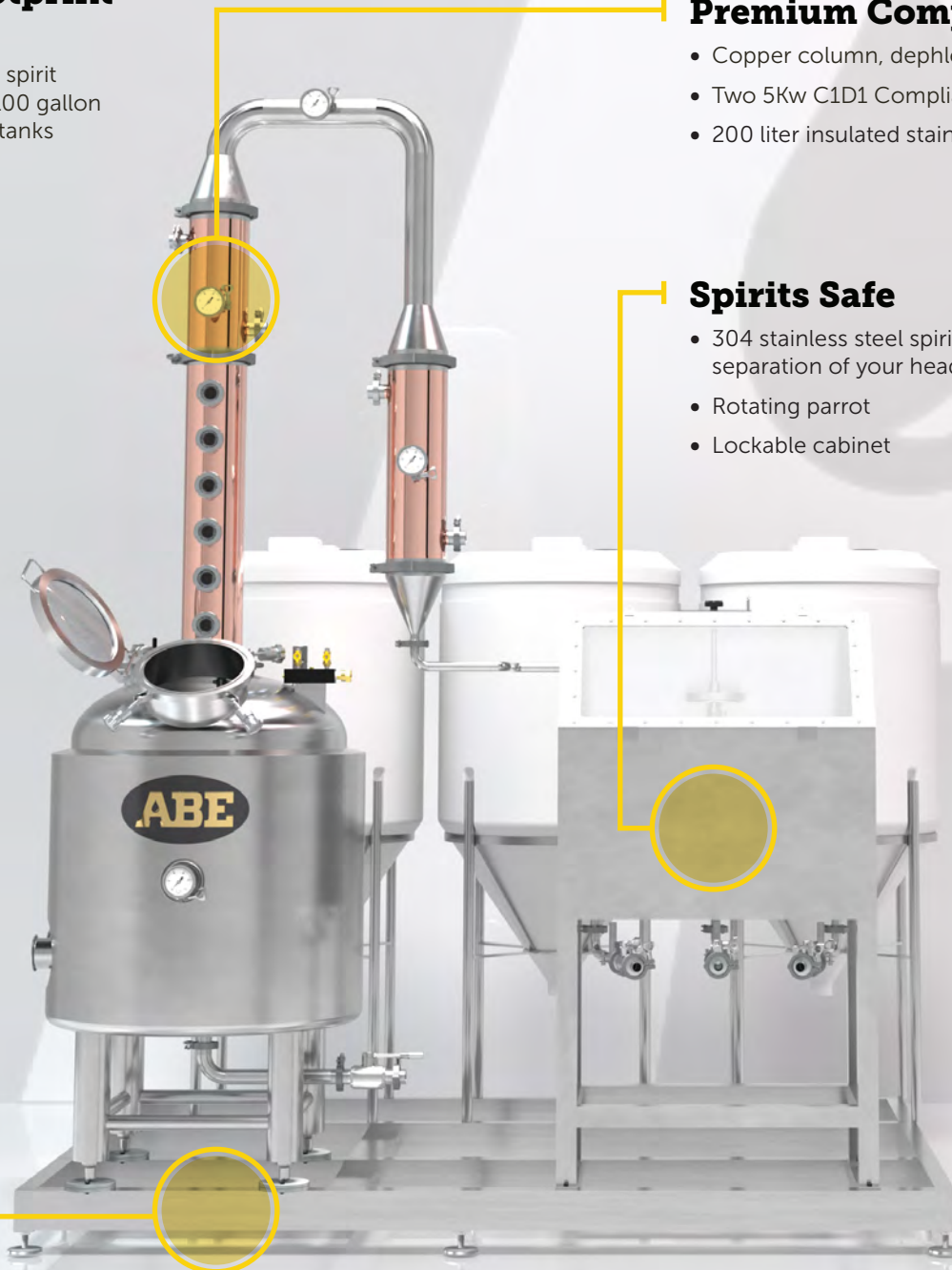

**ABE**  
EQUIPMENT

2001 SW 6th Street | Lincoln, NE 68522 | (402) 475-2337 | [ABEEquipment.com](http://ABEEquipment.com)

# Pilot Skid

## Features

- 200 liter ABE Pilot Still
- Two 5 kw submersible C1D1\* Compliant heating elements
- Copper column
- Manual agitator
- Five PSI PRV/VRV
- Six 6" diameter perforated plates
- 1.5" sanitary drain
- 3/4" water hose connections
- Three polyethylene food grade tanks
- 3/8" push lock water lines
- Condenser water manifold
- Copper dephlegmator
- Copper final condenser
- Removable thermometer in boil pot
- Thermometer in dephlegmator
- Thermometer in Lyne-arm
- Thermometer in final Condenser
- Optional spirits safe

## Your Complete Package

Each Pilot Skid that leaves our facility carries UL certification and an industry-leading five year limited warranty on the metal and welds. In addition to a comprehensive spare parts inventory, you'll receive superior customer support from our team in Lincoln, Nebraska with any ABE purchase.

## Compatible Products

- ABE Mash Skid
- ABE TruPatriot Bottle Filler
- ABE Patriot Fill Station

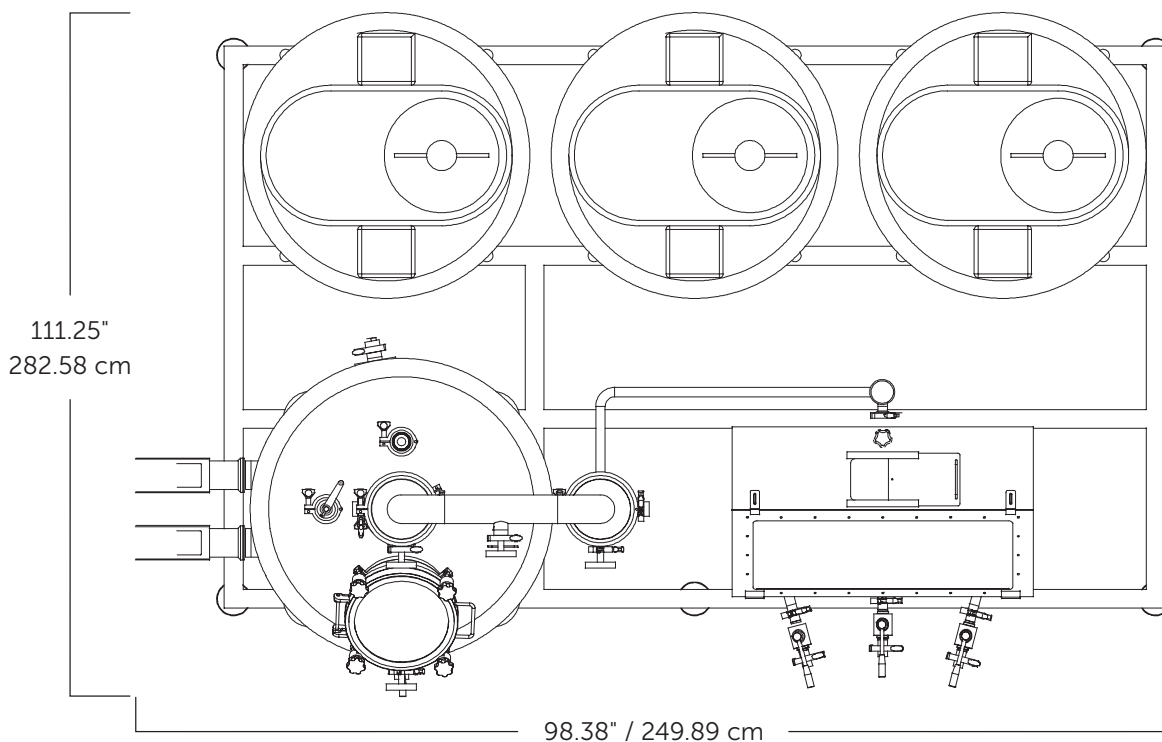

ABE Equipment reserves the right to change specification without notice. All specifications are approximate. ©2024 ABE Equipment